

Modern VVVF Drives

by Lionel Hutt, Donald Vollrath and Casey Carey

Learning Objectives

After reading this article, you should have learned about:

- ◆ Types of VVVF drives
- ◆ The comparison of a VVVF inverter to a vector drive
- ◆ Power consumption of AC-VVVF drives
- ◆ The sizing of a drive
- ◆ Advantages of a DC drive unit

Introduction

The Ward-Leonard drive system for DC motors was invented in 1893 and rapidly became the drive of choice for lift systems. One hundred years later (give or take a year or two), the variable-voltage, variable-frequency (VVVF) drive system for AC motors appeared. Ten years later, it has matured to the 21st Century

drive of choice. This article looks at the basic motor theory and then moves on to discuss types of drives, and how the two are matched. Practical matters such as the correct sizing, EMC, grounding, power consumption, etc. are examined. Finally, future trends and products are predicted.

Speed Control of Asynchronous (Induction) Motors

The synchronous speed of an induction motor is controlled by the number of poles in the motor and the frequency of applied current. Torque is developed by rotor slip (electrical rpm – actual rpm) multiplied by excitation current in the stator. The strength of the motor can be varied by adjustment of the “volts per hertz” ratio applied to the motor windings. Operation is symmetrical in either motoring or regenerative conditions. Synchronous

speed is a function of the applied frequency and may indeed be zero. Full rated and overload torque can be developed at any speed by applying the correct amounts of frequency, current and slip. The “roundness” of the characteristic slip-torque curve in Figure 1 will vary with individual motor designs.

To control an induction motor one must be able to predict, calculate or actually measure rotor slip with a shaft encoder, or let the motor do it. An electronic inverter is used to vary the frequency. A multitude of “volts per hertz” (V/F), “closed loop” and “open

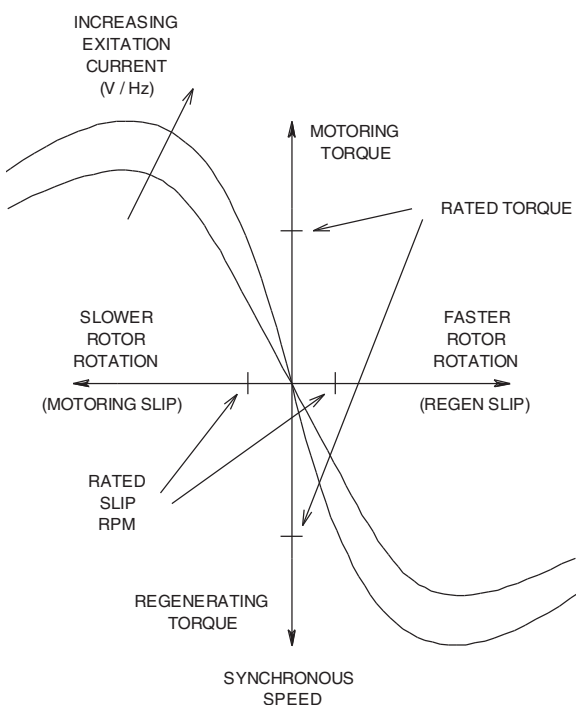

Figure 1 - Asynchronous/induction motor characteristics



Value: 1 contact hour (0.1 CEU)

This article is part of ELEVATOR WORLD's Continuing Education program. Elevator-industry personnel required to obtain continuing-education credits can receive one hour of credit by reading the article and completing the assessment examination questions found on page 117. For this article and more continuing-education opportunities, visit www.elevatorbooks.com



Approved by NAEC



Approved by NAESA International



Approved by QEI Services, Inc.

Approved by the following states:
Florida
Pennsylvania

loop” (encoderless) vector-control schemes exist to control motor current and torque. “Vector” control essentially means that algorithms within the inverter are calculating the relative positions of stator and rotor voltage, current and magneto motive force, in order to control the motor more accurately. Repeatable control of the motor requires knowledge of key motor characteristics, which must remain stable. Modern “vector rated” motors will have well behaved linear characteristics over a wide range of temperatures and rotor slip. Older motor designs may not be so compatible with precision vector control.

Basic Inverter Control of AC Machine

A typical low-cost inverter uses a simple rectifier front-end and a fixed voltage intermediate DC bus to help isolate mains current from that of the motor, as shown in Figure 2. Each motor phase is alternately connected to the + and - terminals of the DC bus in pulse-width-modulation (PWM) fashion so that the average three-phase voltages applied to the motor terminals are sinusoidal at any de-

sired magnitude and frequency. Because a simple rectifier cannot pass power back into the mains supply, a separate “on-off” switch (Figure 3), commonly termed as a “braking chopper,” is necessary to dissipate regenerative energy during the motor’s braking phase into an external dynamic braking resistor, in the form of heat.

Basic inverter controllers exhibit fundamental characteristics:

- ◆ Drives must be compatible with a variety of mains power supplies: one-phase or three-phase, 50/60 hz.
- ◆ VVVF fed to the motor controls its speed and torque.
- ◆ DC bus energy storage isolates the input “front-end” from motor control “back-end.”
- ◆ The motor side can have a different kVA rating than mains power.
- ◆ True power conversion, i.e., “kW in = kW out”
- ◆ Motor and inverter can regenerate mechanical power back into the DC bus.
- ◆ The simple rectifier front end has one-way power flow.

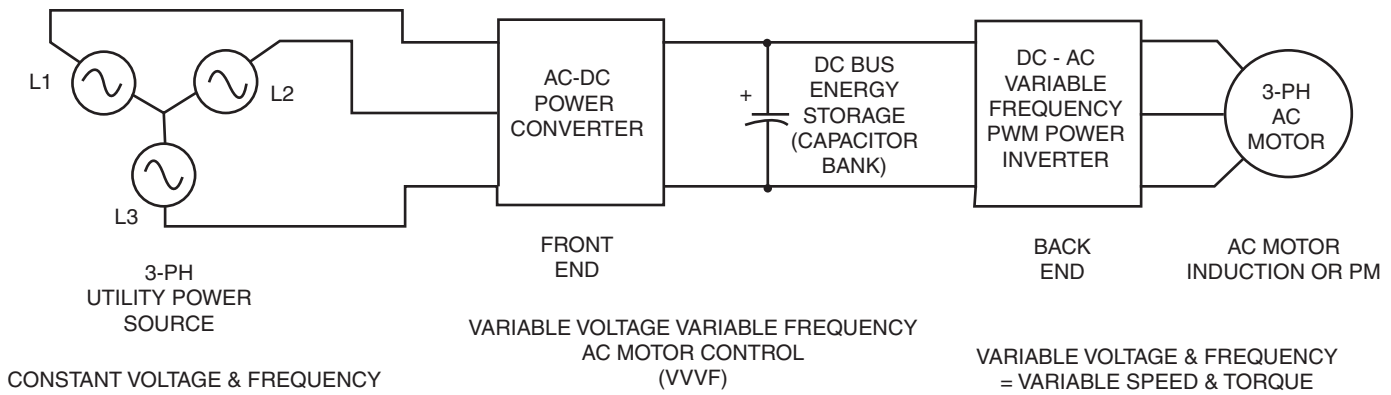

Figure 2 - Basic inverter control

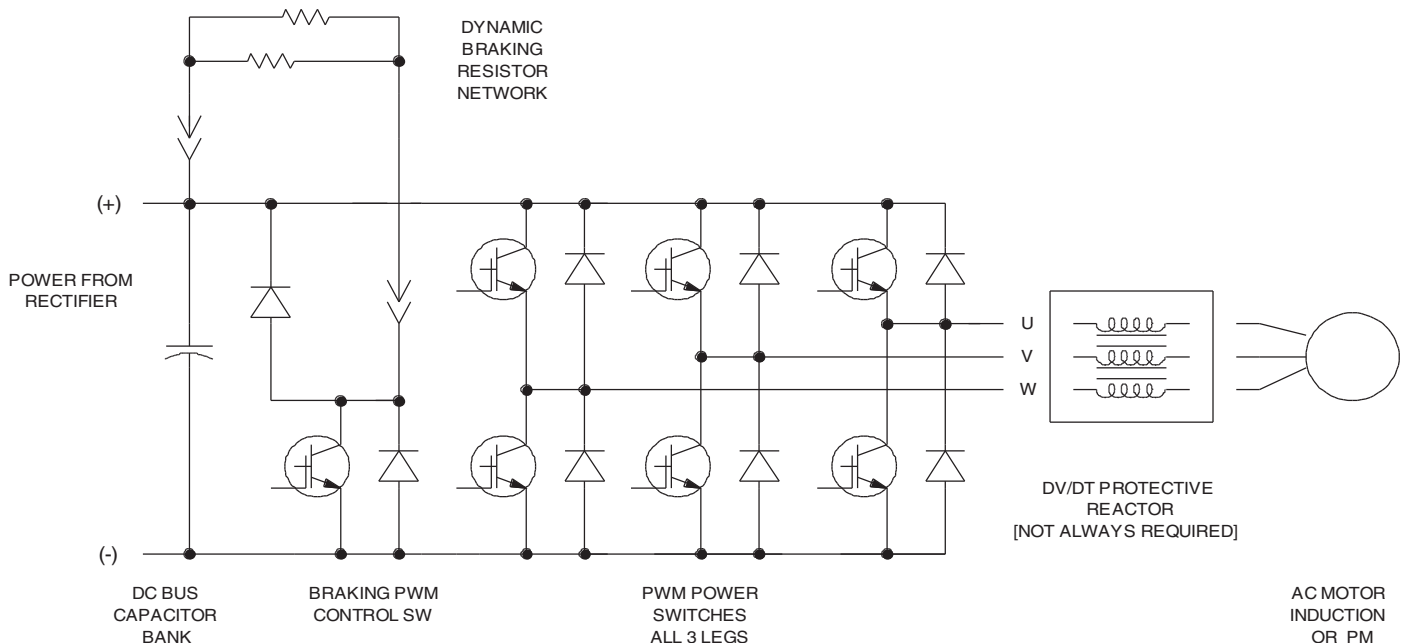

Figure 3 - Typical inverter power section

Advantages

- ▲ Low maintenance system.
- ▲ Provides variable speed control of the motor.
- ▲ Synthesized sinusoidal voltage and current to motor equates to smoother control.
- ▲ Motor and inverter have the ability to regenerate.
- ▲ Independent of power source for DC bus.
- ▲ DC bus power is isolated from mains supply disturbances.

Disadvantages

- ▼ More complex internal operation.
- ▼ The general cost of power components.
- ▼ Separate dynamic braking is required.
- ▼ PWM switching gives rise to increased RFI.
- ▼ Consideration should be given to motor insulation breakdown caused from higher levels of dv/dt.

Table 1 – Advantages and disadvantages of inverter drive control

Fundamental Equations for an AC Asynchronous Induction Motor

$$\text{torque} \sim \text{rpm}_{\text{slip}} \times \text{excitation}$$

$$\text{voltage}_{\text{motor}} \sim \text{rpm}_{\text{speed}} \times \text{excitation} + \text{current} \times \text{stator-impedance}$$

$$\text{rpm}_{\text{slip}} = \text{rpm}_{\text{stator-electrical}} - \text{rpm}_{\text{rotor}}$$

$$\text{rpm}_{\text{stator-electrical}} = 60 \times \text{frequency}_{\text{inverter}} / \text{number of pairs of poles}$$

$$\text{excitation} \sim \text{current}_{\text{stator}} - \text{torque} \times \text{power-factor}$$

As simple as it may appear, operation of the induction motor is complex with many interoperative characteristics. With the correct amount of voltage and frequency applied, the motor will automatically align its internal characteristics (torque, current, speed) to settle on a stable operating point as per the above fundamental equations.

However, the simplest of VVVF inverters can only vary voltage and frequency applied to the motor terminals. For precise control of motor torque, and therefore speed, one must be able to predict what changes in voltage and frequency are necessary in order to produce the desired torque to control actual speed. For elevators, this is particularly important when driving into a landing, as a small error in the estimate of motor slip will produce an obvious error in speed, causing unwanted landing level inaccuracies.

Vector Drive Technology

The power section of a vector drive is identical to that of a VVVF inverter. The main difference is that the vector drive uses a more complex algorithm to control power to the motor. Current transducers are also required to report back actual motor current, which is closely regulated in accordance with known motor characteristics. When combined with encoder feedback to measure slip, full motor torque may be reliably produced at all speeds, including zero mechanical rpm.

When using a vector drive (with encoder), the elevator car can approach the floor, level at very low speeds, and then hold the car stationary at the landing level until the

brake is set. Additionally, vector drives can be used with both geared and gearless machine designs and are often available in sensorless open loop (encoderless) format. Although the performance of these drives is typically better than simple VVVF control, they do not generally allow the same precise control of torque at or near zero speed as closed-loop vector controlled drives. Most AC elevator drives also use a dynamic braking resistor bank to dissipate excess regenerated energy. Additional controls are available for line regeneration and to help comply with relevant guidelines for total harmonic distortion.

V/f Control

- ◆ Indirect control of torque.
- ◆ Control adjusts frequency, not speed.
- ◆ Feedback is based only on fixed electrical values for the current and voltage.
- ◆ Can be made to work with most machines.
- ◆ Normally used DC injection plus the mechanical brake for reliable stopping.

Vector Control

- ◆ Excellent control of torque.
- ◆ Speed is regulated at all speeds.
- ◆ Feedback is from encoder mounted on the motor shaft and measured phase currents.
- ◆ Requires known (and stable) motor characteristics for good results.
- ◆ Vector control can often provide direct reliable position control.

Table 2 – Comparison between V/f and closed-loop vector control

Synchronous Permanent-Magnet (PM) Motor Control

The rotor speed of a synchronous PM motor is controlled directly by the applied frequency. Torque is developed by moving the rotor away from the angular position of the electrical magnetic forces in the stator. The strength of the motor is maintained by adjustment of stator current, manipulated by the voltage applied to the windings. As Figure 4 shows operation is symmetrical in either motoring or regenerative conditions. Full and overload torque can be developed at zero speed (frequency) when sufficient current is applied.

PM Motor Controls

Control of a synchronous motor requires the ability to provide sufficient current to produce the desired torque, but not too much to overheat the motor windings. An inverter is used to vary the frequency, adjust motor voltage and, therefore, current. Rotor angular position is usually measured by the use of a resolver. Modern PM machines are constructed with powerful magnets, limiting them to low rpm gearless elevator machines. However, this does lend itself well to flat, pancake-type designs, which are in themselves ideal for machine-room-less (MRL) applications.

Some servo stepper motors are early versions of PM-AC machines, constructed with discrete magnetic pole

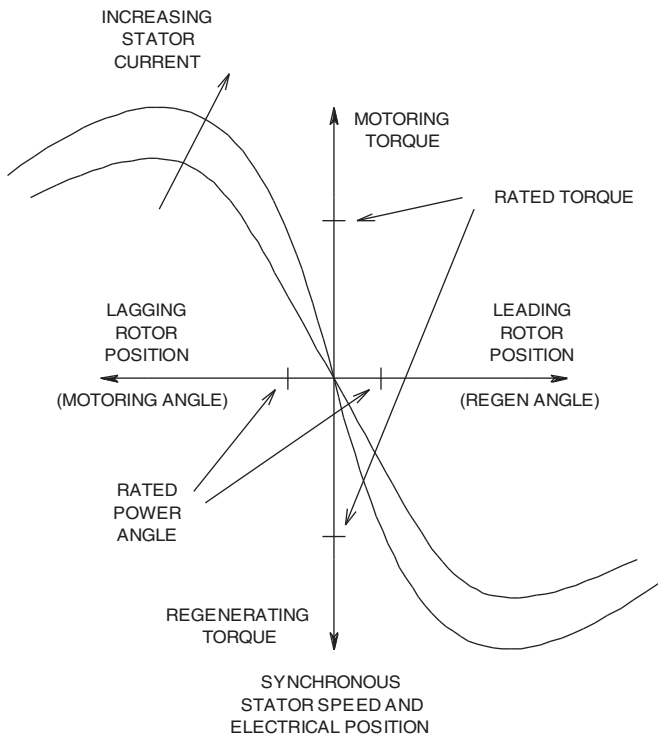

Figure 4 – Synchronous/PM motor characteristics

positions in both rotor and stator that can suffer from torque “cogging” at low speeds. “Brush-less DC” motors are of similar construction with the same salient pole effects. Modern PM elevator machines have almost no magnetic saliency to create cogging, making them ideal for smooth operation near zero speed. However, controlling them can be rather complex. The rotational angle between the poles of the permanent magnets on the rotor and that caused by current in stator windings must be known and controlled in order to produce useful torque and speed, without motor shaft oscillation. A resolver to measure the angular position of the rotor, plus the use of complex, vector-like computations, are required to achieve smooth torque at all speeds. The control mechanisms are slightly different, but the power circuitry of the inverter and motor are essentially similar to that used with standard asynchronous induction machine types.

Power Consumption

Modern AC elevator drives are often the most electrically efficient part of the elevator control apparatus, often exceeding 94%, including the necessary EMC filters. AC motors themselves are typically between 90-96% efficient when running at rated load, although with conventional two-speed or AC-VV type drive systems, the user is penalized during light-load stages of the lift cycle, i.e., full-car-down and empty-car-up where motor loadings are light and resultant power factor is poor.

It is realistic to expect electricity consumption savings of typically 30% upward when an AC-VVVF drive is fitted in place of AC-VV. It is also true to say kWhr consumption for AC-VVVF drives is typically half that of two-speed systems. The other obvious benefits are a more efficient and cooler-running machine, especially during regenerative conditions, where DC injection braking systems are normally required to brake the load. This is because modern drive systems overcome the previous problems associated with DC injection braking, by offering a near-sinusoidal output waveform and constant torque across a wide speed range.

To conclude, one of the main benefits of fitting a variable speed drive is that for all conditions of running load, drive system efficiency will be typically 96-97% and power factor will be approaching unity, resulting in electricity savings by a reduction in kWhr consumption.

Drive Sizing

Each elevator application requires a certain amount of peak and continuous power (kW) to accelerate and lift the load. The choice of motor, gearing and operating voltage will determine the continuous and peak current that must be delivered by the inverter. Even though drives may be rated by kW, continuous and/or peak amperes are often the limiting factor. In essence, the selected drive must accommodate the required peak and running currents of the lift system within its standard “I x t” overload reserve, ensuring that sufficient current can be delivered at the selected switching frequency, also taking into account any required current “derates” when running in high machine room temperature environments.

Selecting an oversized drive does not generally cause any problem other than increased hardware cost and in some cases motor map “mismatch” issues between drive and machine, but this is sometimes necessary to ensure that IGBT power components are always operating within their design capability to ensure longevity of operation from increased reliability. This is particularly important in the case of gearless asynchronous and synchronous machine types, where nominal running frequencies are typically less than 50Hz. Selecting a drive that is undersized can induce reliability issues, the inability to obtain desired ride quality performance or simple inability to lift, accelerate or decelerate the load. It is always essential to follow the manufacturer’s guidelines for reliable operation.

Wherever possible, it is advisable to check the motor nameplate for voltage, frequency, full load rpm and full load current. This may be difficult on older motors, as nameplate data is often illegible or missing. It is very important that accurate full load current, frequency and rpm be known. In order to size the drive correctly and calculate

motor slip, it can be helpful to take measurements of full load motor current, voltage and rpm on existing applications before selecting an inverter size.

Motor slip is also an important motor parameter. Vector drives (both closed loop and open loop) are designed for use with low slip machines. "Low slip" is usually considered less than 5%. "High slip" motors (above 5% slip) are usually associated with open loop (encoderless) control. A closed-loop vector drive will be more difficult to adjust with an older high slip motor, as current regulation becomes more critical with high-resistance rotor machines. Here the onsite guidance of the drive manufacturer should be sought.

Correct Installation Considerations

There are four common features in lift installations. The AC drive unit is mounted on an unpainted back plate within a steel electrical enclosure. The elevator motor is located nearby and is located on a suitable steel bedplate. The velocity encoder is directly coupled to the motor shaft. The elevator car controller may or may not be in a separate electrical enclosure.

Safety considerations require that the metal chassis and cabinet components of all exposed electrical apparatus be connected to earth ground for personnel protection. The manner in which grounding wires are connected and installed can make a difference in the emissions of and sensitivity to electrical noise.

PWM inverters operate by rapidly switching power on and off. Since there is always some capacitive coupling from electrical circuits to other nearby objects, AC drive switching noise will attempt to flow between the motor and drive chassis, and between the drive chassis and other components on the mains supply side. The most effective method of minimizing interference is to give noise current a direct low-resistance path in which to flow, and a higher resistance path to where it is unwanted. The following guidelines will help achieve excellent results.

It is recommended that a grounding conductor bar be provided in the drive enclosure cabinet, electrically bonded to the metal frame, AND a grounding wire be provided to this bar:

- a. Directly from the drive chassis
- b. Directly from the drive panel backplate
- c. Directly from the motor frame
- d. From building steel
- e. From the car controller enclosure

All electrical power wiring should be encased in metal conduit rather than open electrical cable trays. Three-phase wiring for mains input and motor output should be separated. Ground bonding wires, sized to meet or exceed

fault-current requirements of the equipment size, should be routed through the same wiring conduits. It is not recommended that metal conduit connections or building steel be solely relied upon to provide grounding.

The encoder housing and shaft should be electrically insulated from the motor frame and shaft. It is essential to always use shielded cable for encoder wiring, ensuring the shield of this cable only terminates at the receiver (drive) end.

The drive's circuit common should be connected to chassis ground with a wire of suitable cross-section.

All 24V logic signal circuits have their 0V common grounded at the drive. If 24V signaling is used rather than relay contacts, it is essential to provide a wire link between drive controller and car controller circuit commons.

Reliability Considerations

Customers deserve reliable equipment with a long operating life that can only be achieved through excellence in engineering design and manufacturing. This includes a thorough understanding of the stresses caused by repeated elevator cycling, careful selection and qualification testing of critical components through close collaboration with suppliers, control of manufacturing processes, involvement of manufacturing associates in training and continuous quality-improvement programs. Just as important is quick identification of the root causes of manufacturing and field failures, through failure analysis, with closed loop corrective feedback.

Equipment life is established at the design stage, as all components degrade or age with the effects of electrical stress, high temperature or repeated temperature fluctuations. Specifying it to death is not the complete answer. A great deal of experience is also necessary to select the correct components with adequate de-rating from that shown on the data sheet in order to achieve long life performance. Understanding real-life conditions and adding sufficient safety margin to ride through "unexpected" out-of-tolerance conditions in the field is also necessary to improve the drive's "in-field" reliability. Two factors, often overlooked, that will ensure longevity of operation are (1) providing sufficient drive ventilation and cooling as per the drive manufacturer's recommendations and (2) ensuring solid grounding integrity for each and every drive installation.

Future Trends

A greater use of flat-package-style synchronous PM machines, in and out of machine rooms, and higher rpm motors with small-diameter sheaves with Kevlar® ropes or flat belts are expected changes in the industry. Generally, these innovations do not affect the electronic controls of elevator drives. However, additional considerations

may need to be taken to overcome issues such as personnel evacuation under mains-loss conditions for MLR lifts. Other trends that will affect drive technology are:

- ◆ Insulated gate bipolar transistor (IGBT) power devices (“electronic switches”) will become larger and more efficient, leading to larger kW rated AC drives with higher switching speeds to create less acoustic motor noise.
- ◆ The ongoing market push for material cost reduction and the increased awareness of needing to comply with new mains distortion, voltage flicker and noise emissions/immunity standards – Drives will feature active rectifier front ends to reduce current harmonics on mains lines, resulting in increased drive complexity and larger filter components.
- ◆ An ever-tightening focus on energy conservation – Drives with active mains supply regeneration capability will become the standard above 25kW.
- ◆ DC motors will also be powered by PWM switching! – Once larger sized drives with regeneration and harmonic current reduction become available, DC motors powered by the same controller as an AC drive could well become commonplace. This will eventually replace SCR type drives where control of mains supply harmonics is key.
- ◆ Increased position profiling capabilities – With a desire for

Learning-Reinforcement Questions

Use the below learning-reinforcement questions to study for the Continuing Education Assessment Exam available online at www.elevatorbooks.com or on page 117 of this issue.

- ◆ What controls the synchronous speed of an induction motor?
- ◆ What are the characteristics of a braking chopper?
- ◆ What are the seven fundamental attributes of basic inverter controllers?
- ◆ What are the four common features in lift installation?
- ◆ How much energy can installing an AC-VVVF drive save when it is replacing an AC-VV drive?
- ◆ How can equipment life be affected?
- ◆ Which trends are important to the future of drive technology?

combining minimum flight times with optimum ride comfort, we should expect to see an increase in “direct to floor” position profiling. This will potentially serve to reduce the necessary complexity and cost of the car controller itself.

- ◆ Increased commissioning aids – The increased awareness of drive, control and position protocols will essentially replace standard drive control circuit interconnections and allow for increased fault diagnosis capability and reduced commissioning time. Other benefits will include the ability to program drive parameters via the car controller and make drive related ride quality adjustments whilst inside the lift car.
- ◆ Ever-increasing reliability, reduction in unit size and unit cost – There are so many critical design elements where no single factor can be considered more important than all others. But all this comes with a price. The truth is... *You only get what you pay for!*

*Reprinted from **Elevation***

Lionel Hutt is the managing director for Magnetek-UK, Ltd. He has over 10 years of experience applying AC and DC drives to elevators.

Donald Vollrath is a principal engineer for the Magnetek Elevator Products Division with 35 years of related experience with EC, AC and DC motor controls. He has worked to perfect motor drive applications on elevators for nearly 20 years. He is a BSEE graduate of the University of Illinois.

Casey Carey is a senior application engineer for the Magnetek Elevator Products Division. He attended the Milwaukee School of Engineering and has an associate degree from the U.S. Navy. Prior to coming to Magnetek in 1980, Casey worked for the Raytheon Undersea Warfare Center and the Koss Corp.



ELEVATOR WORLD Continuing Education Assessment Examination Questions

Instructions:

- ◆ Read the article **“Modern VVVF Drives”** (page 87) and study the learning-reinforcement questions at the end of the article.
- ◆ To receive **one hour** of continuing-education credit, answer the assessment examination questions found below online at www.elevatorbooks.com or fill out the ELEVATOR WORLD Continuing Education Reporting Form found overleaf and submit by mail with payment.
- ◆ Approved for Continuing Education by **NAEC for CET and NAESAI and QEI Services, Inc. for QEI and for Florida and Pennsylvania State Licenses**

1. What is the purpose of an electronic converter?
 - a. It is used to vary and apply the correct amount of frequency to the motor.
 - b. It changes the power to the motor from AC to DC.
 - c. It monitors the torque to the motor.
 - d. It is very compatible to older motor designs.
2. What does a braking chopper do?
 - a. It helps isolate the main current from that of the motor.
 - b. It regulates the three-phase voltages to the motor terminals.
 - c. It acts as a separate on/off switch that is necessary to dissipate regenerative energy during the motor's braking phase.
 - d. It cuts off all power to the braking circuit.
3. What is expected in electricity-consumption savings when an AC-VVVF drive replaces an AC-VV drive?
 - a. Up to 40%.
 - b. Up to 30%.
 - c. Up to 10%.
 - d. Up to 15%.
4. Which item below is NOT a common feature in elevator-drive unit installation?
 - a. The AC drive unit is mounted on an unpainted back plate within a steel electrical enclosure.
 - b. The elevator motor is located nearby on a suitable steel bedplate.
 - c. The velocity encoder is directly coupled to the motor shaft.
 - d. All power wiring shall be in open electrical-cable trays.
 - e. The elevator controller may or may not be in a separate electrical enclosure.
5. What is a disadvantage of an inverter drive control?
 - a. It is independent of the power source for the DC bus.
 - b. It is a low-maintenance system.
 - c. It requires separate dynamic braking.
 - d. Both the motor and inverter have the ability to regenerate.
 - e. It provides variable speed control of the motor.
6. Which is NOT a fundamental attribute of basic inverter controllers?
 - a. True power conversion.
 - b. The motor side having a different kVA rating than mains power.
 - c. Speed and torque are fed to the motor controls through VVVF.
 - d. Both the motor and inverter can regenerate power back into the DC bus.
 - e. Drives are usually not compatible with mains power supplies.
7. How can precise control of motor torque be obtained?
 - a. By predicting the necessary changes in voltage and frequency in order to produce the desired torque.
 - b. By using the simplest VVVF inverters available.
 - c. By randomly varying voltage and frequency applied to the motor terminals.
 - d. By aligning the motor's internal characteristics to settle on a stable operating point.
8. Power sections of vector drives and VVVF inverters are always different.
 - a. True.
 - b. False.
9. Which of the following does NOT affect equipment life?
 - a. Electrical stress.
 - b. The altitude of the installation.
 - c. High temperature.
 - d. Repeated temperature fluctuations.
10. Which of the following trends will affect drive technology?
 - a. IGBT power devices will become smaller.
 - b. DC motors will no longer be powered by PWM switching.
 - c. There will be less position profiling.
 - d. There will be an increase in commissioning aids.

ELEVATOR WORLD Continuing Education Reporting Form



Article title: **"Modern VVVF Drives"** (EW, February 2010, page 87).

Continuing-education credit: This article will earn you **one contact hour (0.1 CEU)** of elevator-industry continuing-education credit.

Directions: Select one answer for each question in the exam. Completely circle the appropriate letter. A minimum score of 80% is required to earn credit. You can also take this test online at website: www.elevatorbooks.com.

Last name: _____

First name: _____ Middle initial: _____

CET®, CAT® or QEI number: _____

State License number: _____

Company name: _____

Address: _____ City: _____

State: _____ ZIP code: _____

Telephone: _____ Fax: _____

E-mail: _____

This article, **"Modern VVVF Drives,"** is rated for one contact hour of continuing-education credit. Certification regulations require that we verify actual study time with all program participants. Please answer the below question.

How many hours did you spend reading the article and studying the learning-reinforcement questions?
hours _____ minutes _____

Circle correct answer

- | | |
|--------------|--------------|
| 1. a b c d | 6. a b c d e |
| 2. a b c d | 7. a b c d |
| 3. a b c d | 8. a b |
| 4. a b c d e | 9. a b c d |
| 5. a b c d e | 10. a b c d |

Signature: _____

Payment options:

Check one: \$30.00 – Non-subscriber course fee
 \$25.50 – ELEVATOR WORLD subscriber course fee
 Subscriber #: _____
 (6 digit number on your print label or in your digital confirmation.)

Payment enclosed
 (check payable to Elevator World, Inc.)

Charge to my: VISA

MasterCard

American Express

Card number: _____

Expiration date: _____

Signature: _____

To receive your certificate of completion using the mail-in option: Send the completed form with questions answered and payment information included to: Elevator World, Inc., P.O. Box 6507, Mobile, AL 36660.

To receive your certificate of completion online, visit website: www.elevatorbooks.com and follow the instructions provided for online testing.

You now have the opportunity to earn Continuing Education contact hours in ELEVATOR WORLD magazine. Articles pertain to various industry topics which appear in the magazine bi-monthly and for every exam you successfully complete you'll earn 1–3 contact hours.

As a subscriber, you not only have full access to these Continuing Education articles, but you also receive 15% off of the retail price.

Your subscription & all Online Continuing Education Courses can be purchased at

elevatorbooks.com

ELEVATOR WORLD'S ONLINE BOOKSTORE

Your Subscription to
ELEVATOR WORLD
 has just become more valuable.

